



Cable Mat

Installation Manual

FHM-T & MiniMatD 04-20

Table of Contents

150/200 W/m² Cable Mat

Introduction	1	Cable Mat Important Installation Guidelines
	2	Tools & Materials Needed for Installation Kit Contents Glossary of Terms
Electrical Requirements	3	Electrical Requirement Power, Cable Mat, Conduit & Sensor Rough-In
Testing & Product Specification	4	Warranty Validation Floor Sensor Resistance Test Insulation Test Cable Mat Heater Specification
Installation	5	Subfloor construction Plan heating mat layout Electrical & Floor preparation
	6	Position and fix heating mat Modifying Cable Mat
	7	Multiple Cable Mat installation Electrical Connection
	8	Important Points for the Tiler Curing Time
Troubleshooting	9	Checking for breaks Checking for electrical shorts Locating a break or Electrical short Cable repair
Warranty	10	Warranty
	11	Install Test Record & Warranty Registration
Miscellaneous	12	Notes

Introduction

Please read carefully before proceeding with installation

Cable Mat Product

Amuheat Cable Mat has been designed and developed to exceed all relevant standards, ensuring installation is quick and simple.

It features a tough twin heating conductor cable pre attached to a fibreglass mesh, with tape strips or adhesive backing for fixing to the floor, yet still allowing unlimited adjustment of the heating element to suit any room layout.

Experienced product design ensures for a simple and quick installation of floor heating with guaranteed and even heat across the complete floor surface.

Cable Mat is available in two output types:

150 watts per m² (for use in living rooms, kitchens, bedrooms, etc)

200 watts per m² (for use in bathrooms or living rooms with high heat losses)



Important Installation Guidelines

- ✓ Take some time to plan the layout considering all obstacles e.g. kitchen cupboards, bathroom sinks etc. Ensure mat will fit before starting
- ✓ Use flexible tile adhesives and grouts
- ✓ If a floor sensor is required, ensure it is inserted in a conduit sealed at the floor end (to ensure easy removal of floor sensor if required after installation) and installed between two heating elements
- ✓ Maintain a 50-80mm cable spacing between the heating element runs or where heating cable is stripped from the mesh for free form layouts
- ✓ Take care not to damage the heating element and cold tail whilst screeding/tiling
- ✓ Ensure all the blue heating element is covered with the screed
- ✓ Make certain there are no air gaps underneath tiled areas or between tile and screed
- ✓ Concrete subfloors must be fully cured before installation commences and timber subfloors must be rigid and free from movement by using a suitable tile backer board (FC Sheet) or insulation board
- ✓ Ensure all the blue heating elements are installed within the floor avoiding crossing the heating element, floor sensor wire or cold tail leads over or under each other and one another
- ✓ Multiple heating mats connect to the thermostat in parallel - the cold tail leads cannot be joined and buried in the ground
- ✓ Do not leave surplus matting rolled up under cabinets and do not cut, shorten or lengthen the heating element
- ✓ Do not drop or rest any heavy objects or tools on the heating element.
- ✓ Do not bang tiling tools on the floor area with heating element to remove excess mortar from the trowel and do not use a knife to clean adhesive from between the tiles along the grout spacing
- ✓ Do not cut or shorten the blue heating cable
- ✓ Do not leave surplus matting rolled up under cabinets and do not cut, shorten or lengthen the heating element
- ✓ Do not switch your under floor heating system on for a minimum of 7 days after tiling to allow correct curing of tile adhesives and grouts.
- ✓ Make sure all electrical work is done by a qualified electrician with connection to a mains power supply connected via a RCD circuit

Introduction

Please read carefully before proceeding with installation

Tools & Materials Needed for Installation

You will require the following items to install Cable Mat

- Floor primer (primer supplied with tile adhesive or use other ie. Bondcrete with water 1:4 ratio)
- Paint tray and roller to apply floor primer
- Scissors (to cut the fibreglass mesh)
- Permanent marker or construction crayon
- Tape measure
- Chisel & hammer or angle grinder (to recess cold tail joints & conduits in floor if required)
- Cardboard or carpet scraps (to protect the heater if tiling is delayed)
- 2 x 20mm Conduit (one for cold tail lead & one for floor sensor)
- Wall box, plate or c-clip (for mounting thermostat)
- RCD switch on electrical board (supplied and fitted by your electrician)
- You may require a 20A contactor if you are installing multiple heating mats connected to one thermostat where the load capacity exceeds 16A

Kit Contents

- Cable Mat heater
- Element fault monitor
- Digital wall thermostat controller
- Floor temperature sensor
- Cable Mat installation guide
- Thermostat installation guide
- Thermostat operating guide
- Warranty registration



Glossary of Terms

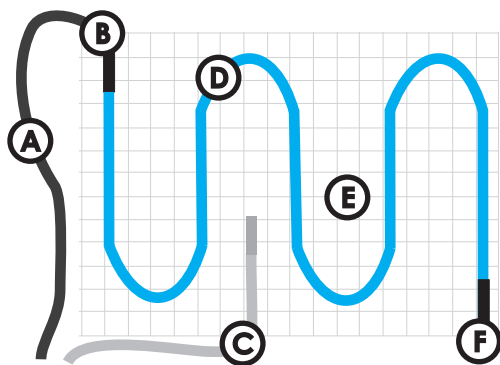

Cable Mat Construction



Heating
Element Profile

- A Cold tail power lead
- B Factory-made cold tail joint
- C Floor temperature sensor
- D Twin heating element
- E Fibreglass mesh with tape strips or adhesive backing
- F Built in heating cable return
- G Twin heating conductor
- H Primary Teflon insulation
- I Steel earth braid
- J Thermoplastic polymer insulation

Electrical Requirements

150/200 W/m² Cable Mat

Electrical Requirement

Before installing Cable Mat you should make allowance for the electrical connections. **If connecting multiple heating mats with an electrical load greater than 16A to one thermostat, you will require a suitably sized electrical contactor.**

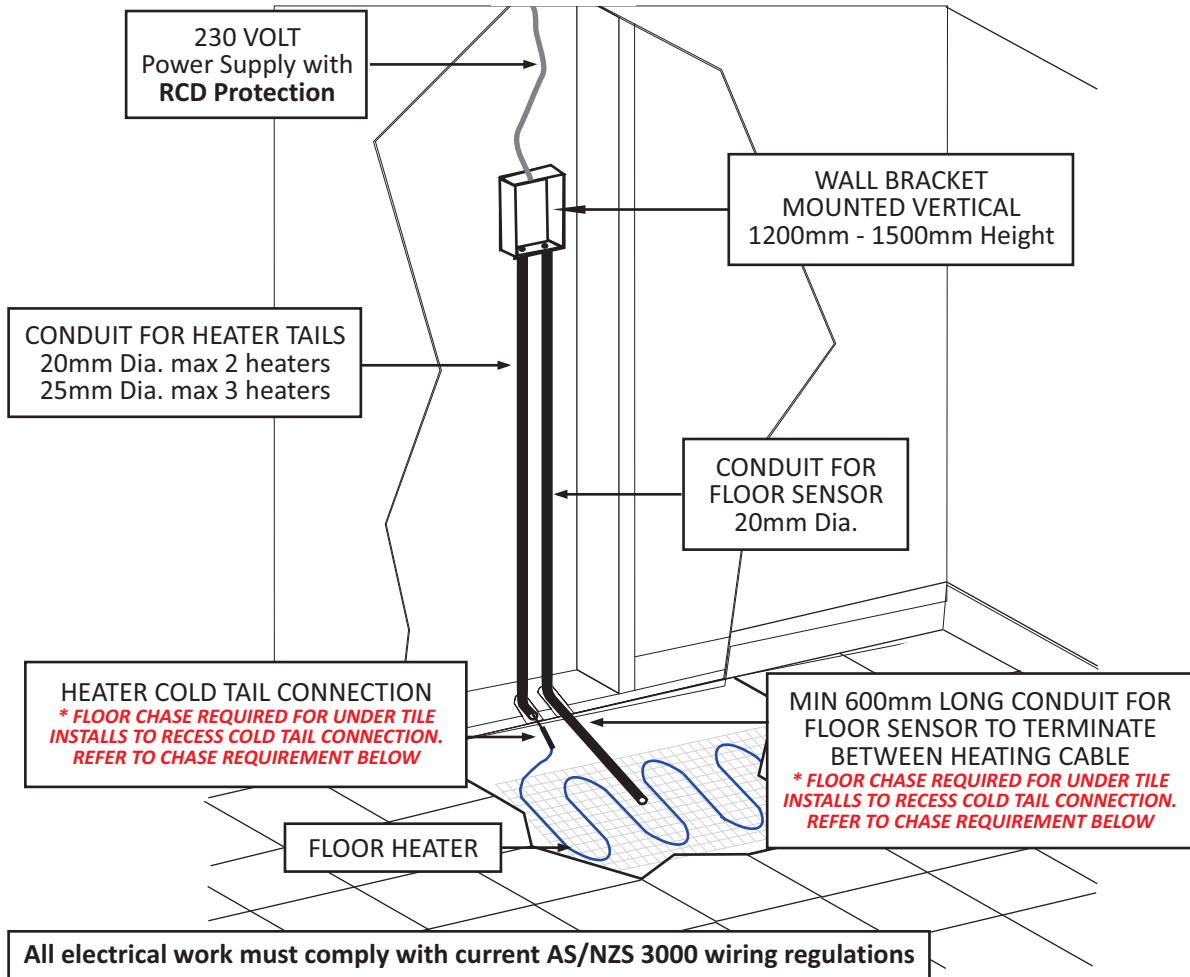

Under Tile Floor Chase Requirement

For Under heating installations, the floor will need to be chased to allow the sensor conduit and cold tails to be recessed into the floor. Once in place you need to glue it down.

Before waterproofing in bathrooms, chase the floor to allow the sensor conduit and cold tails to sit flush with the floor level.

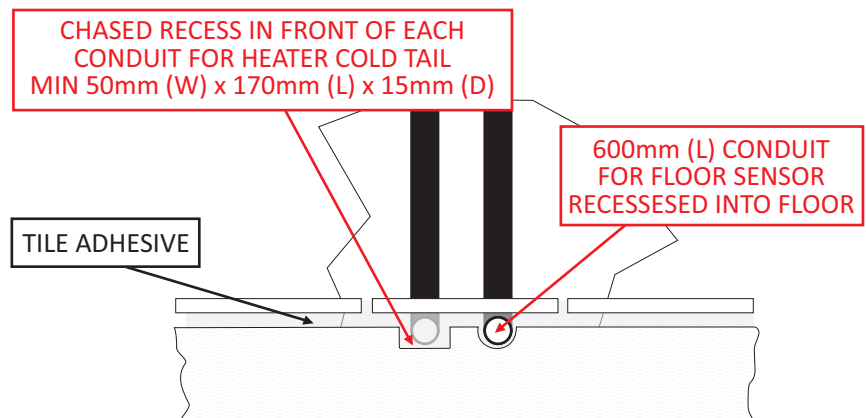

Testing & Product Specification

150/200 W/m² Cable Mat

Warranty Validation

Cable Mat is tested and supplied in good working order from our factory. To ensure the integrity of the system, an insulation and resistance test on the heating cable should be conducted before, during and after heater and floor installation. This information should be recorded on the Installation Test Record sheet to validate the 20 year extended manufacturers product warranty.

Resistance Test

This test is carried out to ensure continuity exists in the heating element. Using a multimeter on ohm setting, place one probe on the active conductor and the other on the neutral conductor (brown and blue leads on cold tail) and confirm the resistance value matches the factory test result within +/- 10% of the value marked on the product specification label and/or table below.

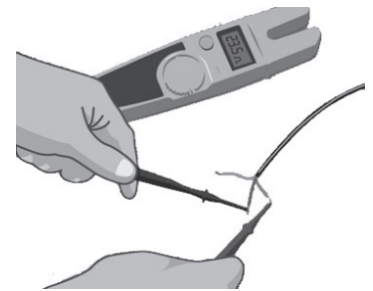

Floor Sensor Resistance Test

If installing the thermostat floor temperature sensor, test for resistance as above. The range on the multimeter should be set to Auto or 20K Ohm. *Resistance readings for NTC 10K sensors should be 10K Ohm and NTC 100K sensors should be between 100K Ohm at 25°C.*

Insulation Test

This test is performed to measure the insulation resistance between conductors and ensures the cable insulation is not damaged. A low resistance reading indicates a damaged cable and must be repaired or replaced. The insulation resistance tester should be connected between the conductors (blue and brown cables) and the earth braid (yellow/green cable). The meter should set to 500V and record a high resistance value.

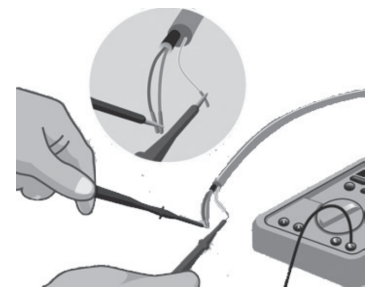

200 W/m²

Code	Coverage	Mat Size (m)	Watt @ 230V	Ohm Resistance +10–5%
CM200-20T	1m ²	2 x 0.5	200	264.5
CM300-30T	1.5m ²	3 x 0.5	300	176.3
CM400-20T	2m ²	4 x 0.5	400	132.3
CM500-20T	2.5m ²	5 x 0.5	500	105.8
CM600-20T	3m ²	6 x 0.5	600	88.2
CM700-20T	3.5m ²	7 x 0.5	700	75.6
CM800-20T	4m ²	8 x 0.5	800	66.1
CM900-20T	4.5m ²	9 x 0.5	900	58.8
CM1000-20T	5m ²	10 x 0.5	1000	52.9
CM1200-20T	6m ²	12 x 0.5	1200	44.1
CM1400-20T	7m ²	14 x 0.5	1400	37.8

150 W/m²

Code	Coverage	Mat Size (m)	Watt @ 230V	Ohm Resistance +10–5%
CM750-15T	5m ²	10 x 0.5	750	70.5
CM900-15T	6m ²	12 x 0.5	900	58.8
CM1200-15T	8m ²	16 x 0.5	1200	44.1
CM1500-15T	10m ²	20 x 0.5	1500	35.3
CM1800-15T	12m ²	24 x 0.5	1800	29.4
CM2250-15T	15m ²	30 x 0.5	2250	23.5

Installation

150/200 W/m² Cable Mat

Step 1 - Subfloor Construction

Suitable sub-floors must be correctly designed, constructed and prepared in accordance with building regulations. Cable Mat can be installed on concrete slab, existing tiles, acoustic underlay, FC Sheet board and above any of these subfloors whose surface is coated with a waterproof.

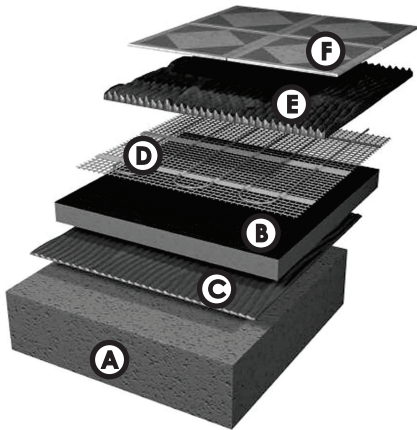

Cable Mat On
Concrete Subfloor

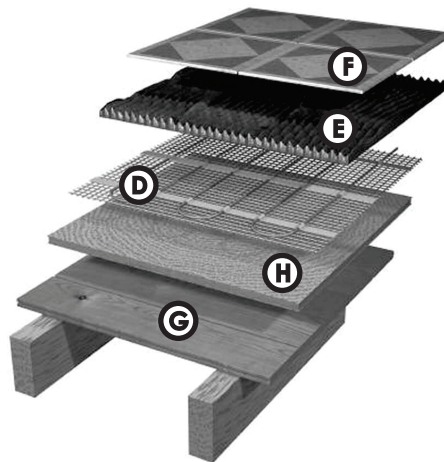

Cable Mat On
Timber Subfloor

- A Concrete/Screed Subfloor
- B Insulation (optional)
- C Glue
- D Cable Mat
- E Sand Cement Screed &/or Tile Adhesive
- F Tile Floor Finish
- G Timber Subfloor
- H Tile backer board (FC Sheet)

Our recommendation is only intended to provide an outline guide of suitable subfloors and preparation work required before installing Cable Mat.

Step 2 - Plan heating mat layout

Plan your heating mat layout by drawing your room including all fixed items e.g. toilet sink kitchen benches etc, then confirm the size of heating mat you have purchased is correctly sized for the floor area to be heated. From the thermostat position (start point) sketch the proposed layout to ensure the heated area is completely covered whilst using all of Cable Mat.

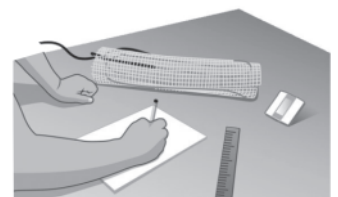

Step 3 - Electrical & floor preparation

Cable Mat is supplied with a single cold tail lead which should run from the floor to the thermostat in a single 20mm conduit (limit 2 heating mats per conduit). A separate conduit is required, extended and positioned to lay between two heating cables, for the thermostat floor sensor. The heater cold tail joints and conduits should be covered by the sand cement screed. The floor sensor conduit should be sealed to prevent adhesive or screed entering it. *Refer to Electrical Requirements.*

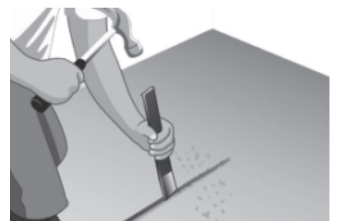

Prepare the floor by removing all loose particles thoroughly and seal with primer supplied with tile glue (or Bondcrete mixed 1:4 with water).

Installation

150/200 W/m² Cable Mat

Step 4 - Position & fix heating mat

Starting from the floor directly beneath the thermostat location, unroll the heating mat until you reach the end of your first run. Ensure the heating mat is placed on the floor with the heating cable underneath the mesh (see below for more info on modifying Cable Mat).

When you reach the end of the first run carefully cut the mesh in between two heating cables (do not cut the blue heating cable) and turn the mat to its new position. Ensure heating cable remains between 50-80mm apart and also ensure the mesh does not overlap. Continue this process.

In some instances it may be necessary to free form the heating cable around fixtures and fittings by cutting the heating cable and mesh free from long runs. Ensure the heating cable is laid with spacings between 50-80mm apart.

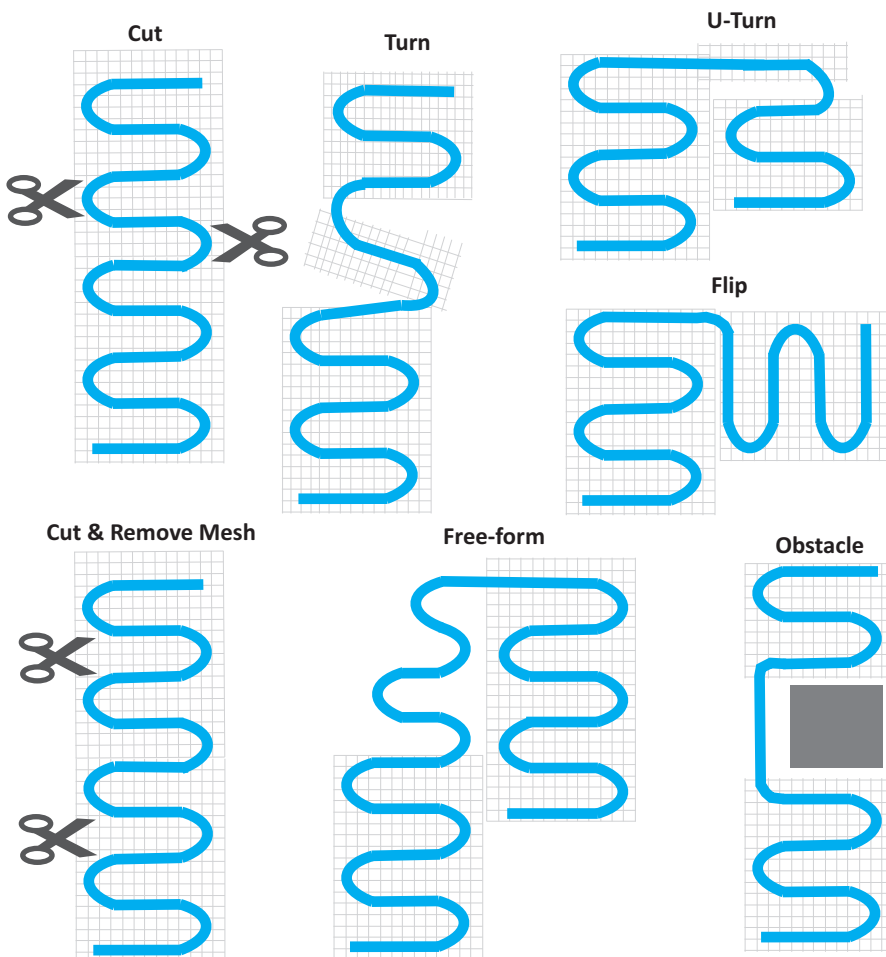
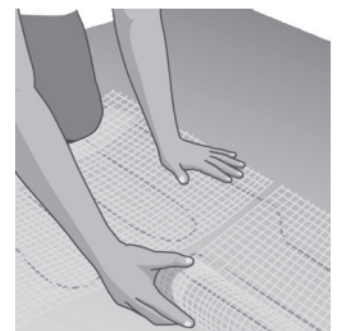
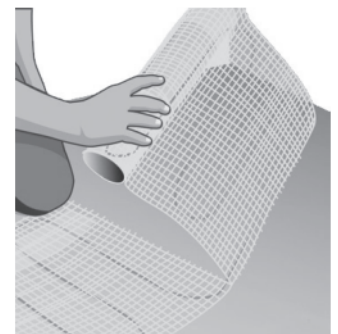
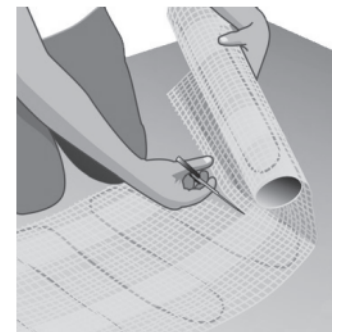

Installation

150/200 W/m² Cable Mat

If you are installing multiple heaters into one room and using one thermostat, you will need to ensure all the cold tail leads start and finish at the same point. Do not join the cold tail leads or heating elements wire together.



Once complete, remove the peel away tape or film and stick the heating mat to the floor. Free form runs should also be fixed to the floor using cloth tape.

Step 5 - Electrical Connection

Amuheat thermostats are supplied with a floor sensor accessory, which must be fed into a dedicated conduit from behind the thermostat, with its ending at floor level fixed between two heating cables. Where required, this conduit can be recessed into the subfloor.

Before tiling commences, Cable Mat must be tested to ensure no accidental damage to the heating cable has occurred during the installation. The battery operated fault monitor should then be connected to the heating mat cold tail leads to monitor for damage during the flooring installation.

FOR MULTIPLE MAT INSTALLATIONS, NEVER JOIN THE POWER SUPPLY CABLES UNDER THE TILE FLOOR. NO SERIAL CONNECTIONS OF ONE MAT TO ANOTHER PANEL. NO DAISY-CHAINS.

A QUALIFIED ELECTRICIAN MUST CONNECT THE POWER SUPPLY CABLES TO THE THERMOSTAT, AND CONNECT THE THERMOSTAT TO THE SUPPLY.

Note

These installation instructions are NOT intended to replace or supersede the installation instructions provided by the manufacturer of tile or adhesives, but to supplement them. BOTH sets of installation instructions should be complied with. In the event of any apparent contradiction between instructions, contact Amuheat for clarity on how to proceed.

Installation

150/200 W/m² Cable Mat

Important Points for the Tiler

Ensure the heating element fault monitor is connected to the heating system and switched on before tiling. Stop all works if the alarm is sounding or the red light is on.

Ensure you use tile adhesives and grouts suitable for use with underfloor heating systems (they must contain a flexible additive). It is important that each tile is solidly bedded in tile adhesive, with no gaps or voids beneath them.

Avoid unnecessary foot traffic. Heavy cardboard or carpet scraps should be used to protect the heating cables from traffic during the floor installation.

Care should be taken to not damage the heating cable when bedding or leveling the sand cement mixture over Cable Mat.

Do not use one trowel to lift tiles, use two.

Do not store any materials or tools over the exposed heating wires.

Do not use grinder to cut in expansion joint in the slab - this will damage the heating cable.

Avoid mixing or shoveling the sand cement mixture over the heating cable.

Avoid using wheelbarrows over the heating mat.

Curing Time

Ceramic tile and stone installations require up to 14 days for the adhesive to cure. Allow the adhesive to fully cure before the floor heating system is switched on. Failure to do so may result in damage to flooring by cause the adhesive to become brittle.



Troubleshooting

150/200 W/m² Cable Mat

Checking For Breaks

To determine if there is a break in the heating cable under the floor:

- Set the multimeter to measure in 0-200 Ohms.
- Place one probe on the active conductor and the other on the neutral conductor.
- Confirm your reading falls within +/- 15% of the recorded value before installation.
- If you have absolutely no reading (= infinity on your meter), then there is a break (= total cut) in the conductor.

Checking For Electrical Short

To determine if there is a short in the heating cable under the floor:

- Set the multimeter to measure in 0-200 Ohms.
- Place one probe on the active conductor and the other on the corresponding earth wire.
- Confirm your reading is open circuit or infinity.
- Repeat this step on the neutral conductor and it's corresponding earth wire.
- Place one probe on the active conductor and the other on the active earth wire.
- If you have continuity between either the active-earth or neutral-earth combinations, there is a short in the heating cable.

Locating a Break or Electrical Short

There are several ways to locate breaks or circuit shorts mathematically or with underground fault detectors. For more information, contact Amuheat Support.

Cable Repair

- Cut the damaged piece of heating cable out
- Using a knife blade, carefully strip the outer PVC layer from both ends of the exposed heating cable.
- Separate and twist the earth core away from the inner conductor on both ends of the exposed heating cable.
- Using an open flame, burn the inner Teflon layer from the conductor wire from both ends of the exposed heating cable.
- Measure the length of electrical wire required to join the two exposed ends of the heating cable, and using the knife blade, strip away some of the insulation.
- Using a ferule or solder connect the one end of the heating cable conductor to a piece of electrical wire.
- Slide a piece of heat shrink over the join, and seal under an open flame.
- Slide a second piece of heat shrink over the electrical wire. Using a second ferrule or solder, connect the other end of the electrical wire to the other exposed heating cable conductor. Slide the second piece of heat shrink over the join and seal under an open flame.
- Repeat these steps to repair the earth wire.
- Conduct resistance and insulation tests on the heating cable prior to connection. Compare the results with those taken before, during and after the heating and flooring installation.
- Recess the join in a chiseled channel and cover with hot glue melt.

Warranty

150/200 W/m² Cable Mat

Warranty

Important Note: Mandatory Australian Consumer Law statement

This warranty is provided in addition to other rights and remedies held by a consumer at law. Our goods come with guarantees that cannot be excluded under the Australian Consumer Law. You are entitled to a replacement or refund for a major failure and for compensation for any other reasonably foreseeable loss or damage. You are also entitled to have the goods repaired or replaced if the goods fail to be of acceptable quality and the failure does not amount to a major failure.

Amuheat warrants, at its option, to repair or replace Cable Mat if found to be faulty or defective in manufacture or materials during the warranty period.

The warranty period is 2 years, commencing on the date of purchase (please retain a copy of your invoice which will be required in the event of a claim). *As of 1 April 2020, you are invited to extend your product warranty from 2 years to 20 years by simply registering your installation with Amuheat by returning a copy of the Warranty Card & Install Test Record. The registration must occur within 60 days of the date purchase.*

This warranty is a parts only warranty and does not cover field labour.

Where it is determined Cable Mat is defective in material, and has not been damaged as a result of misuse or misapplication, Amuheat will repair or replace the heating mat. If the repair is not feasible, Amuheat will at its option replace or refund the original cost of the heating mat.

Warranty conditions & exclusions

The warranty does not cover faults caused by incorrect design by others / misuse / damage caused by others / damage in transit / incorrect installation and any other subsequent damage that may occur. Repair / replacement will be fully chargeable if the damage is because of any of the above reasons.

Amuheat disclaims any warranty not provided herein. Amuheat further disclaims any responsibility for any consequential damages arising from ownership or use of the product, including inconvenience, loss of use or ongoing costs of operating the heating system.

For invalid claims under this warranty, the end user will be liable for the costs of making the warranty claim including any service call costs.

How to make a warranty claim

To make a warranty claim, call Amuheat and be ready to provide information as recorded on the Install Test Record (ie. the model and serial/batch number, date of installation & purchase details) and a full description of the problem.

Alternatively, you can email your warranty claim to warranty@amuheat.com.au or by post to: Amuheat Warranty Claim, 1/13 Brumby Street, Seven Hills NSW 2147.

Proof of purchase and as well as proof of installation in accordance with the accompanying Cable Mat installation guide and local building and electrical codes, including but not limited to the heater being connected to a working RCD safety switch and connected to an approved Amuheat control device, may be required by Amuheat.

Product liability and product safety

Amuheat should be informed immediately about any potential product safety concerns within and outside the warranty period. Amuheat is well aware of its product liability and product safety obligations and responsibilities. It is our aim to ensure appropriate product safety standards are met in order to avoid injury, loss and damage caused by defects in any Products.

Warranty

150/200 W/m² Cable Mat

Complete the form below to register your warranty

Cable Mat comes with a 2 year manufacturer's product warranty. As of 1 April 2020, you are invited to extend your product warranty from 2 years to 20 years by simply registering your installation with Amuheat by returning a copy of the Warranty Card & Install Test Record by email to warranty@amuheat.com.au or by post to Amuheat Warranty Claim, 1/13 Brumby Street, Seven Hills NSW 2147. To qualify for the extended product warranty, registration must occur within 60 days of the date purchase.

Heater Model																		
Serial Number																		
Purchase Date																		
Install Date				Invoice Number														

Installer

Company																			
Full Name																			
Phone																			
Email																			

Test Record

	Before Install	After Install	Pre-Commission
Continuity	YES / NO	YES / NO	YES / NO
Resistance	Ohm	Ohm	Ohm
Insulation	M-Ohm	M-Ohm	M-Ohm

Owner/Tenant

Company																				
Full Name																				
Address 1																				
Address 2																				
Suburb																				
State																		Code		
Phone																				
Email																				



Unit 1, 13 Brumby Street, Seven Hills NSW 2147
Tel: (02) 9114 6934 Fax: (02) 8211 5180
sales@amuheat.com.au www.amuheat.com.au

© 2020 Amuheat Pty Limited